

0915360001

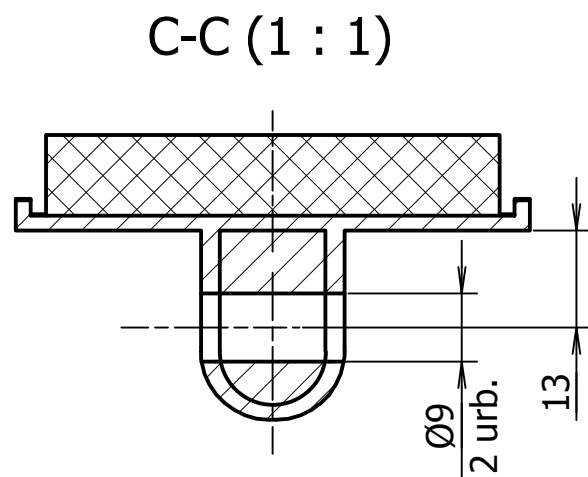
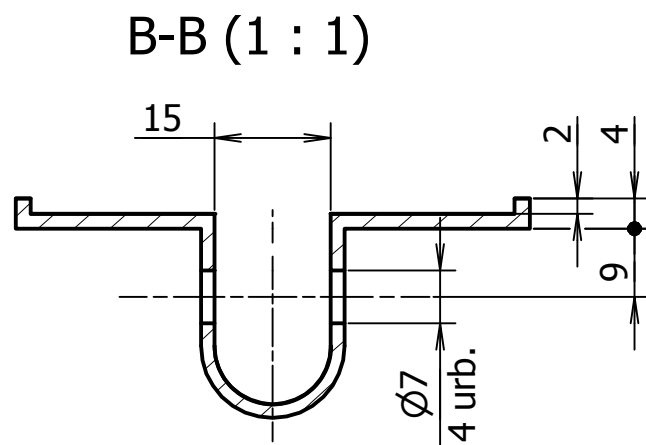
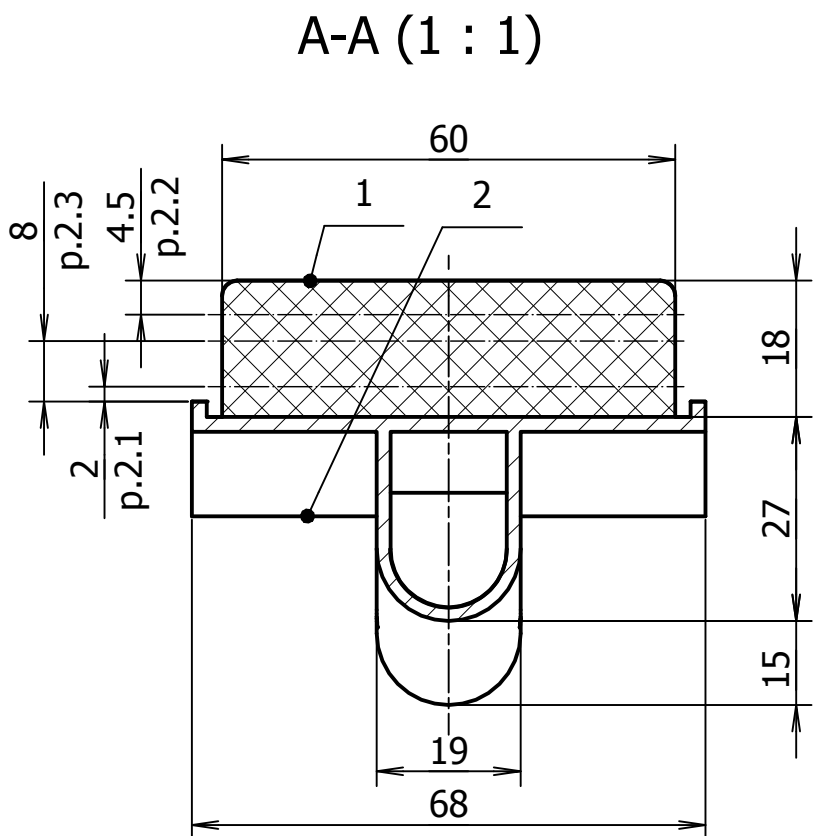
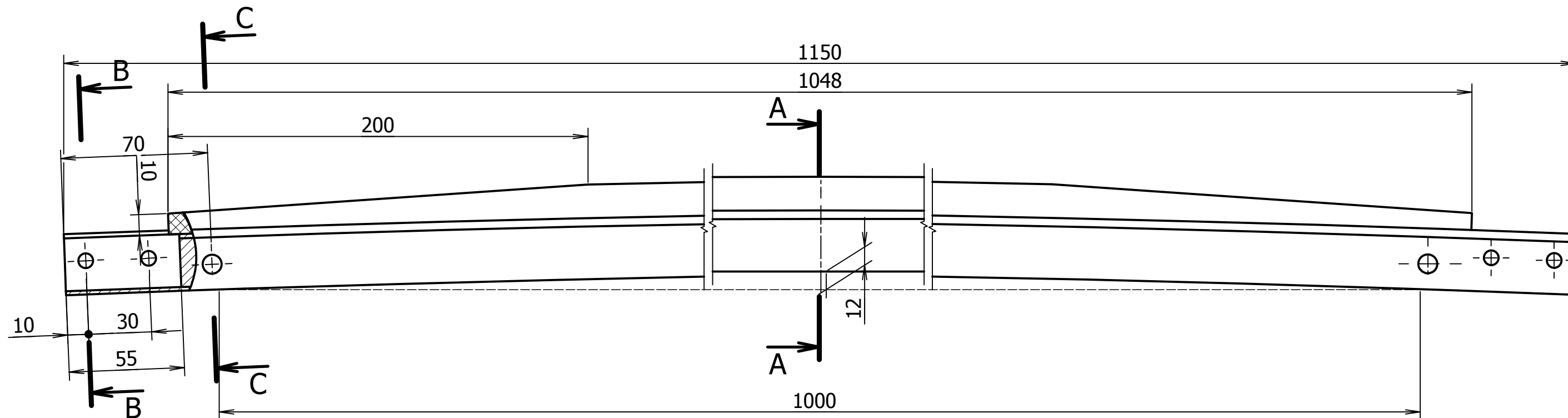

1. Tehniskās prasības.
  - 1.1. Izmēri uzziņām.
  - 1.2. Grafīta plāksnes marķējums: RH84M6 11/16 FA 158077 013.
  - 1.3. Cietība: HRB 5/150 - 115.

2. Eksploatācijas prasības.
  - 2.1. Eksploatācijā pieļaujamais maksimālais grafīta plāksnes nodilums līdz pamatnes apmalei 2 mm.
  - 2.2. Krusteņa darbības zonā no iedobes maksimālā nodiluma līdz grafīta plāksnes augstākajam punktam ne vairāk kā 4.5 mm.
  - 2.3. "Zig-zag" darbības zonā (600 mm) grafīta plāksnes augstums līdz pamatnes apmalei pēc frēzēšanas ne mazāks kā 8 mm.

| Formats                    | Poz. | Apzīmējums     | Nosaukums         | Skaitis  | Piezīme  |                            |  |      |      |        |  |         |     |  |  |      |          |  |  |  |   |   |  |  |  |                |  |  |  |
|----------------------------|------|----------------|-------------------|----------|--|----------------------------|--|------|------|--------|--|---------|-----|--|--|------|----------|--|--|--|---|---|--|--|--|----------------|--|--|--|
| BR                         | 1    |                | Grafīta plāksne   | 1        |  |                            |  |      |      |        |  |         |     |  |  |      |          |  |  |  |   |   |  |  |  |                |  |  |  |
| BR                         | 2    |                | Alumīnija pamatne | 1        |  |                            |  |      |      |        |  |         |     |  |  |      |          |  |  |  |   |   |  |  |  |                |  |  |  |
| <b>0915360001</b>          |      |                |                   |          |  |                            |  |      |      |        |  |         |     |  |  |      |          |  |  |  |   |   |  |  |  |                |  |  |  |
| Izm.                       | Lapa | Dokum.Nr.      | Paraksts          | Dat.     | <table border="1"> <tr> <td colspan="2" rowspan="2">Grafīta plāksne ar pamatni</td> <td>Lit.</td> <td>Masa</td> <td>Merogs</td> </tr> <tr> <td></td> <td>3.60 kg</td> <td>1:2</td> </tr> <tr> <td colspan="2"></td> <td>Lapa</td> <td colspan="2">Lapu sk.</td> </tr> <tr> <td colspan="2"></td> <td>1</td> <td colspan="2">1</td> </tr> <tr> <td colspan="2"></td> <td colspan="3">RĪGAS SATIKSME</td> <td></td> </tr> </table> | Grafīta plāksne ar pamatni |  | Lit. | Masa | Merogs |  | 3.60 kg | 1:2 |  |  | Lapa | Lapu sk. |  |  |  | 1 | 1 |  |  |  | RĪGAS SATIKSME |  |  |  |
| Grafīta plāksne ar pamatni |      | Lit.           | Masa              | Merogs   |  |                            |  |      |      |        |  |         |     |  |  |      |          |  |  |  |   |   |  |  |  |                |  |  |  |
|                            |      |                | 3.60 kg           | 1:2      |  |                            |  |      |      |        |  |         |     |  |  |      |          |  |  |  |   |   |  |  |  |                |  |  |  |
|                            |      | Lapa           | Lapu sk.          |          |  |                            |  |      |      |        |  |         |     |  |  |      |          |  |  |  |   |   |  |  |  |                |  |  |  |
|                            |      | 1              | 1                 |          |  |                            |  |      |      |        |  |         |     |  |  |      |          |  |  |  |   |   |  |  |  |                |  |  |  |
|                            |      | RĪGAS SATIKSME |                   |          |  |                            |  |      |      |        |  |         |     |  |  |      |          |  |  |  |   |   |  |  |  |                |  |  |  |
| Izstr.                     |      | Sokolovs       |                   | 06.06.18 |  |                            |  |      |      |        |  |         |     |  |  |      |          |  |  |  |   |   |  |  |  |                |  |  |  |
| Pārb.                      |      | Nikolajevs     |                   |          |  |                            |  |      |      |        |  |         |     |  |  |      |          |  |  |  |   |   |  |  |  |                |  |  |  |
| T.kontr.                   |      |                |                   |          |  |                            |  |      |      |        |  |         |     |  |  |      |          |  |  |  |   |   |  |  |  |                |  |  |  |
| N.kontr.                   |      |                |                   |          |  |                            |  |      |      |        |  |         |     |  |  |      |          |  |  |  |   |   |  |  |  |                |  |  |  |
| Apst.                      |      |                |                   |          |  |                            |  |      |      |        |  |         |     |  |  |      |          |  |  |  |   |   |  |  |  |                |  |  |  |

0915360010